

5.  Open fuel shut-off valve, if engine is equipped. Move choke control to CHOKE or START position.

Note: Choke must fully close. Move throttle control to RUN or FAST position. If engine is equipped with rocker style stop switch, push RUN or I (= Ignition) before starting.

Rewind Starter:

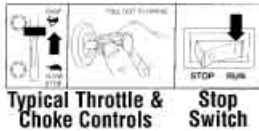

Grasp rope handle and pull slowly until resistance is felt to

prevent kickback. Then pull cord rapidly to overcome compression and start engine. Repeat if necessary with choke off and throttle control in FAST position. Operate engine in FAST position.





6. **GETTING STARTED:** Push machine to the location of the first hole. Start engine and allow to reach operating temperature. Standing at the rear of the machine at the control handle. To begin digging a hole, pull the right hand side of the control lever. This will cause the auger to turn in a clockwise direction. Apply downward pressure to begin digging the hole. If dirt remains in the hole use an up and down motion to clear excess dirt. Release the control lever to stop auger. To reverse the auger rotation (counter-clockwise), pull the left hand side of the control lever.
7. The amount of force exerted will depend on the hardness and type of ground conditions.
8. Remember, the DHS is a single person operation, designed for earth drilling. There may be holes that will be extremely difficult, if not impossible, to drill.
9. If ground is too hard to drill or the auger is jamming on ground conditions or foreign objects (eg. wire, tree roots, etc.), the pressure relief will function, stalling the auger rotation. Clear auger and start again. The operator presence control will ensure quick stop if hand is removed from control lever.

NEVER TIE OR JAM LEVER INTO THE ON POSITION (FORWARD OR REVERSE). REVERSE (COUNTER CLOCKWISE) MAY BE REQUIRED TO UNSCREW JAMMED AUGERS.

10. Do not attempt to drill auger to full depth in one operation. Continually clearing the hole in an up and down motion will facilitate a much easier drilling operation. It may be necessary to clear cutters and auger flighting from time to time to ensure quicker and easier cutting.
11. Remember, as in drilling a hole in steel, one needs a sharp drill. Auger, teeth and pilot **MUST** be in good condition if the auger is to work correctly. See wear parts section for more information.
12.  Auger motor head assembly may be tilted as per incline when drilling on slopes. **DO NOT** change the digger position during drilling. **DO NOT operate on a slope that exceeds 15°**
13. **DO NOT** over reach. Ensure proper footing and balance when working with this machine.
-  **WARNING! – Keep hands and feet clear of all moving parts at all times!**
WARNING! – Keep hands and feet clear of exhaust muffler during or soon after operation.
14.  **WARNING! – in case of difficulty, release the control lever to stop the auger. All digging action stops.** Press the engine "STOP" button located on the engine. (See illustration)
15.  **DO NOT OPERATE CLOSE TO EDGES OR EXCAVATIONS ETC. CHECK FOR ELECTRICAL AND GAS LINES BEFORE DIGGING**
16. **Stop Engine:** Do not move choke control to CHOKE position to stop engine. Backfire or engine damage may occur. Move throttle control to SLOW position, then push rocker switch to 0 (STOP), or turn key to OFF, if equipped.

AFTER USE

- 1)  Turn fuel tap to "OFF" position.
- 2)  Allow machine to cool down. Wash mud and dirt off of the hydraulic post hole digger. Ensure no water enters the carburettor.
- 3) Remove any objects that may have wrapped around the auger.



Typical Stop Switches



SAFETY PRECAUTIONS AND OPERATING INSTRUCTIONS

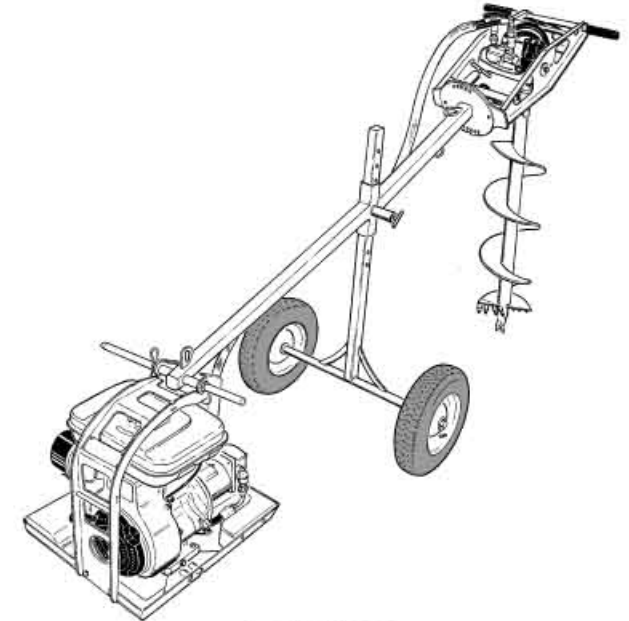

DHS HYDRAULIC POST HOLE DIGGER

 **REDROO.com**
Commercial Outdoor Power Equipment

SAFETY PRECAUTIONS FOR DHS USERS



USE COMMON SENSE AND PLENTY OF IT

- 1)  **DO NOT** allow any person to operate the hydraulic post hole digger without first reading and understanding the safety precautions and operating instructions. **KNOW THE CONTROLS AND HOW TO STOP THE HYDRAULIC POST HOLE DIGGER QUICKLY IN AN EMERGENCY. RELEASE CONTROL LEVER TO STOP AUGER.**
- 2) **NEVER** allow children or untrained adults to operate the hydraulic post hole digger.
- 3) **ALWAYS** wear protective clothing when operating the hydraulic post hole digger. This includes, but is not limited to: safety glasses, hard hat, loose fitting gloves, steel capped boots and hearing protection. **NEVER** wear loose fitting clothing or jewellery when operating the hydraulic post hole digger. Keep all clothing away from moving parts. Items could become caught in the machine, resulting in injury.   
- 4) **ALWAYS** use hydraulic post hole digger in a well lit area.
- 5) **ALWAYS** make certain the hydraulic couplings are properly connected prior to starting the engine.
- 6)  **NEVER** operate hydraulic post hole digger on a slope that exceeds 15°. Digging holes on an incline is dangerous and not recommended.
- 7)    Police the area before digging. Remove any foreign objects in the digging area eg bricks, rocks, wire and sticks. Locate and mark any sprinkler heads, water pipes, gas lines, electrical and telephone cables or any other hazard either below or above ground.
- 8)  **DO NOT** allow other persons near the hydraulic post hole digger. It is up to the operator to keep bystanders and animals a minimum of 6 metres away from the machine while in operation.

- 9) **NEVER** operate the hydraulic post hole digger when fatigued. **ALWAYS BE ALERT!** If you get tired while operating the hydraulic post hole digger, take a break. If you have any type of physical or mental condition that may be aggravated by strenuous work, check with your physician before you operate this equipment. **NEVER** operate the hydraulic post hole digger under the influence of medication, alcohol or drugs.
- 10)  **ALWAYS KEEP YOUR HANDS, FEET AND BODY AWAY FROM THE AUGER WHILE THE MACHINE IS IN USE.**
- 11) **DO NOT** leave the machine unattended while the engine is running.
- 12) **DO NOT** overspeed the engine or alter the governor settings. Excessive speed is dangerous and will shorten engine life.
- 13)  **WARNING:** Keep away from exhaust muffler during or soon after operation.
- 14)  **NEVER** operate the hydraulic post hole digger in an enclosed area. Engine exhaust contains carbon monoxide, an odourless and tasteless poison.
- 15)  **WARNING:** Hydraulic oil is under extreme pressure and can get under and burn or poison. **DO NOT** operate unit with leaking or faulty hose connections or worn, cut hydraulic lines.
- 16)  **STOP** the engine and disconnect the spark plug lead(s) and allow engine to cool before inspecting or performing maintenance on the hydraulic post hole digger.
- 17) **REFUELLING**
 - * Shut off engine. **DO NOT REFUEL AN ENGINE WHILE OPERATING!**
 - * Allow engine to cool. Minimum 5 mins.
 - * **USE UNLEADED FUEL ONLY. Use clean, fresh unleaded fuel.**
 - * **Do not mix oil with unleaded fuel.**
 - * Do not over-fill fuel tank. Allow space for fuel expansion.
 - * Do not smoke near equipment.
 - * Allow no naked flame or hot material in refuelling area.

 - * Use only approved fuel containers and funnels. Remember, fuel is a potential hazard.
 - * Refer to engine owners manual for full details.

“STAY ALERT – DON’T GET HURT”

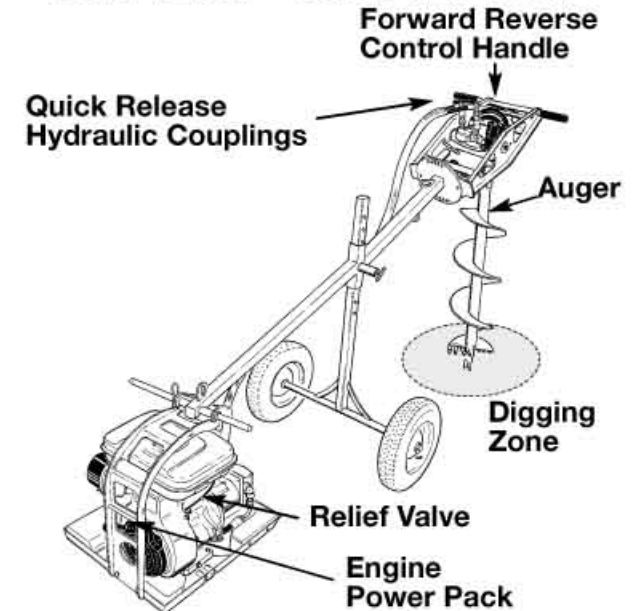

OPERATING INSTRUCTIONS

OPERATION

1.  Familiarize yourself with the machine and its controls.
2. The hydraulic post hole digger is designed to dig vertical and selected offset holes.
3. Make sure the fasteners are properly secured, hydraulic hoses properly connected, and digger frame completely assembled prior to use. **DO NOT ATTEMPT TO START OR RUN ENGINE WITHOUT HYDRAULIC COUPLINGS CONNECTED. DO NOT DISCONNECT HYDRAULIC CONNECT QUICK COUPLINGS WHILE THE ENGINE IS RUNNING.**
4. Auger Installation
 - a) Remove shaft locking collar
 - b) Insert Auger
 - c) Replace shaft locking collar.